

NOTE 1 ALTERNATE MARKING: STICKER OR STAMP

F4	45410	ISO-G 3/4 (INT- HEX), TH = 27,1	CD000006
F3	45397	ISO-G 1 INT. HEX., TH = 27,1	CD000001
F2	45410	ISO-G 3/4 (INT- HEX), TH = 27,1	CD000006
F1	45397	ISO-G 1 INT. HEX., TH = 27,1	CD000001

Pos	Article No	Title / Denomination, code, material, dimension etc	Drawing No./ref	Pos	Article No	Title / Denomination, code, material, dimension etc	Drawing No./ref
-----	------------	---	-----------------	-----	------------	---	-----------------

Title		B10TH/1P-SC-S	
	Created Date	2025-01-04	Created By
	Article/Configuration number	084250.0	Drawing number
		AU	
		AU00075569_084250.0	

Rev No	Alteration	Date	Checked	Approved
10	ADDED DIMENSION. TITLE UPDATED.	28. 1. 2013	SKZE	PDM

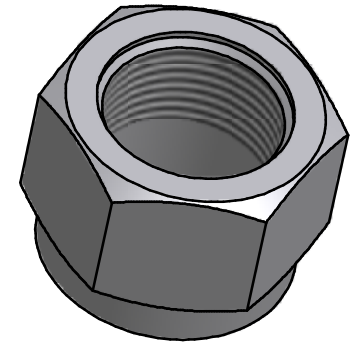
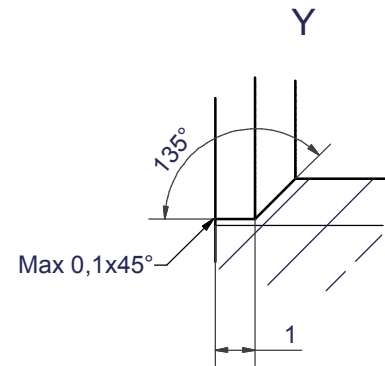
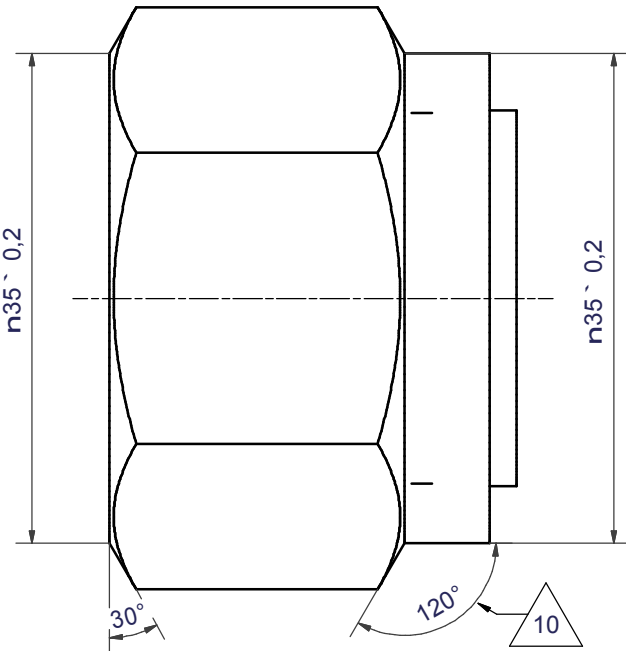
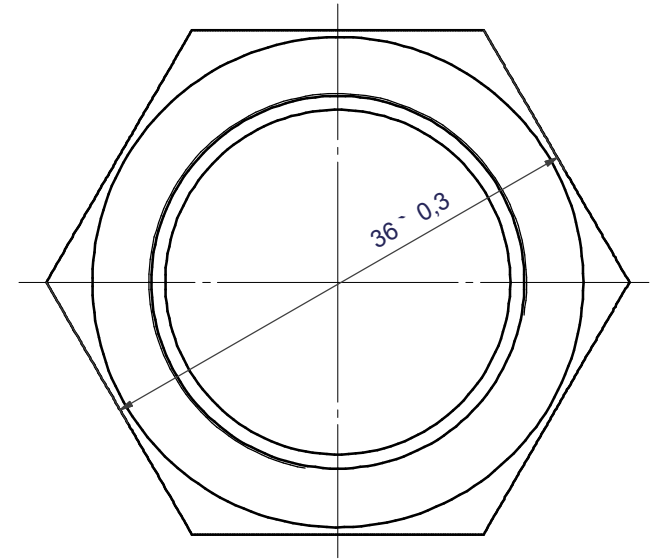
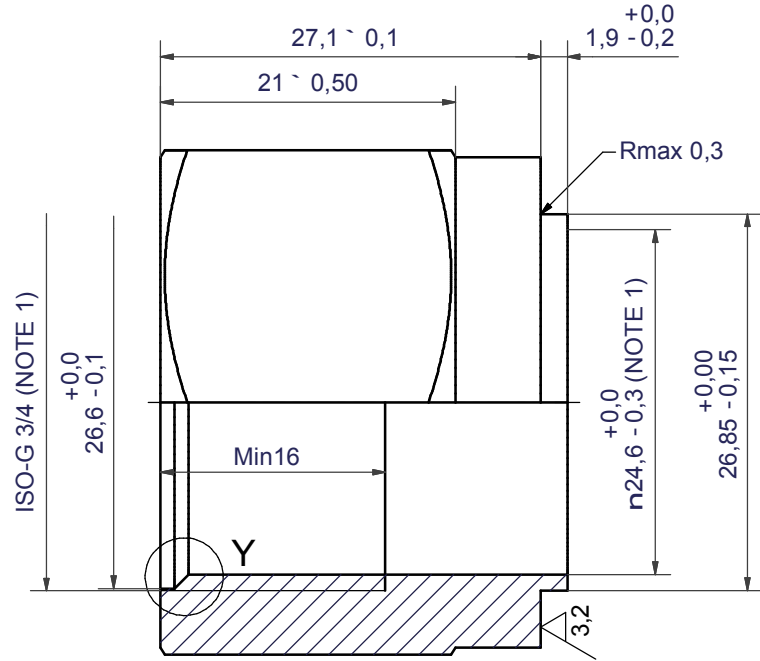

NOTE 1: THREADS MAX INNER DIAMETER SHOULD BE WITHIN SPECIFIED HOLE TOLERANCE
 NOTE 2: DEBURR SHARP EDGES; MAX 0,4

Drawn HR	Checked TP	Approved PDM	Created Date 31. 8. 1992	General geometrical tolerancing ISO 2768 m	General surface finish R _a 3.2	Scale -	Paper size A3
 A DOVER COMPANY		Title ISO-G 3/4 (INT- HEX)					
		Article / Tool number CD	Design Type CD000006	Drawing number 10	Revision 1 (1)	Sheet 1 (1)	

Rev No	Alteration	Date	Checked	Approved
14	DIMENSION CORRECTED	2014-06-02	SKMTB	VP

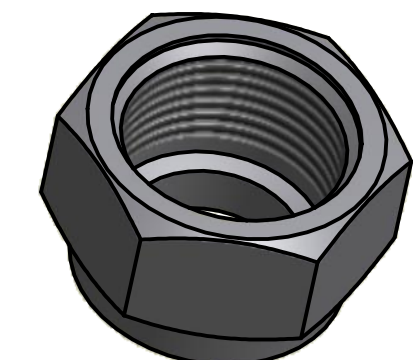
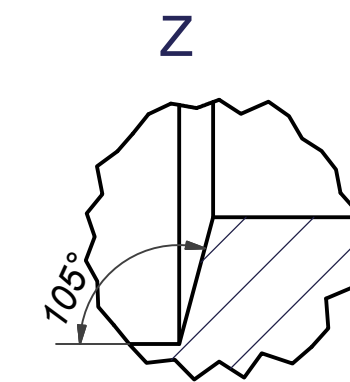
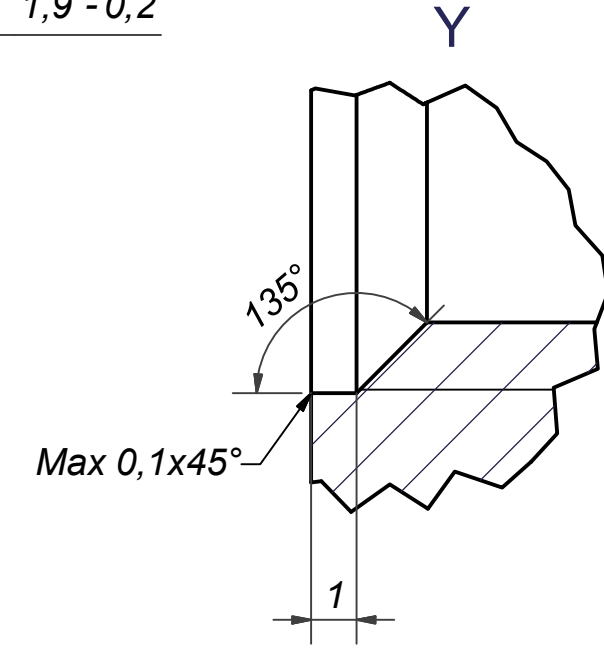
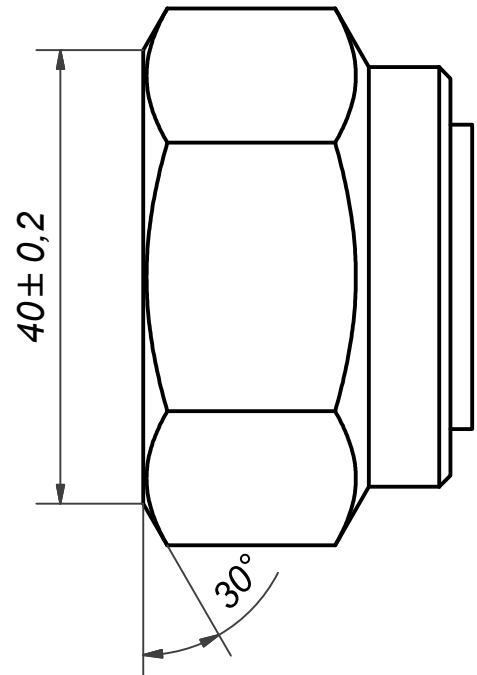
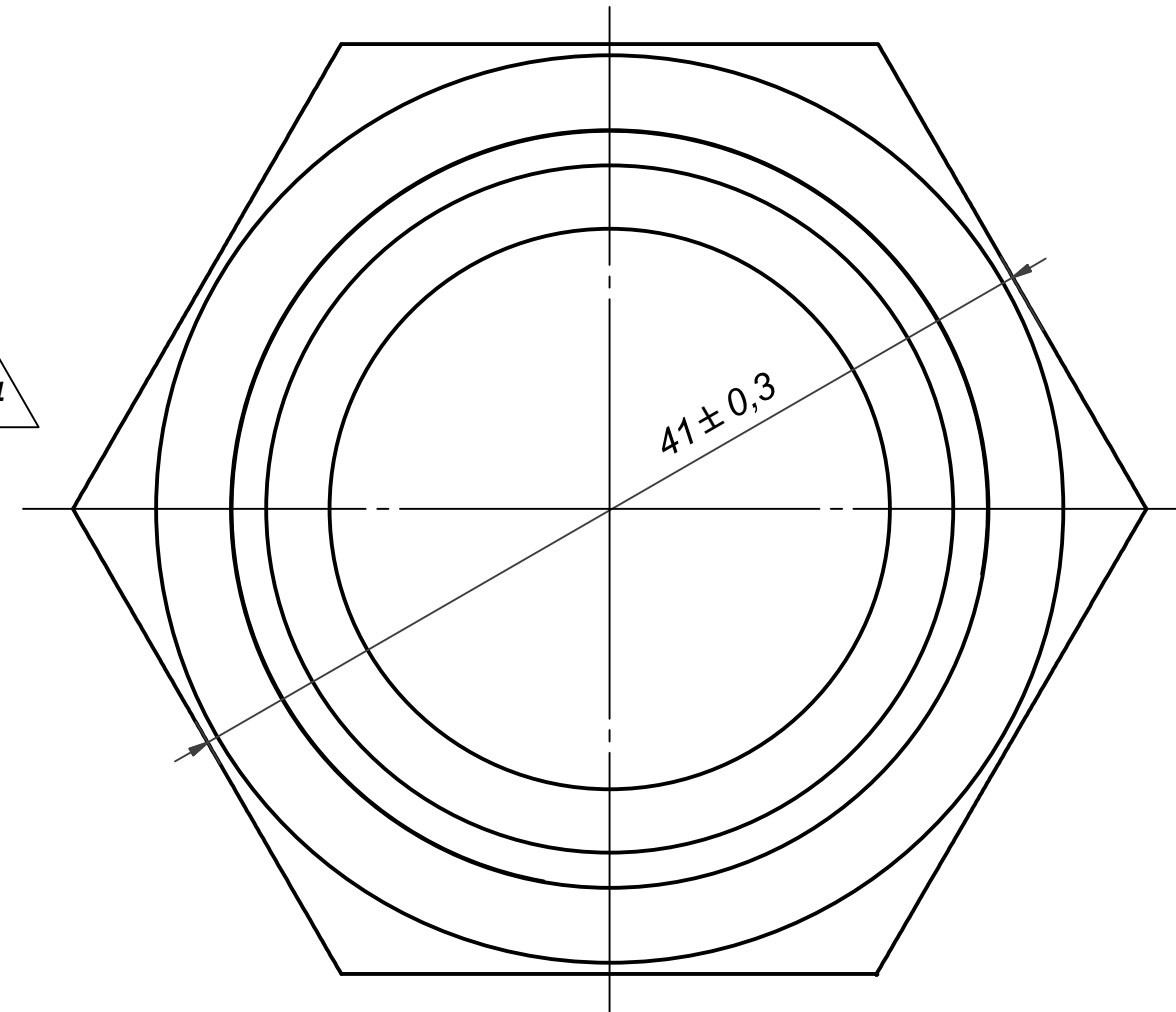
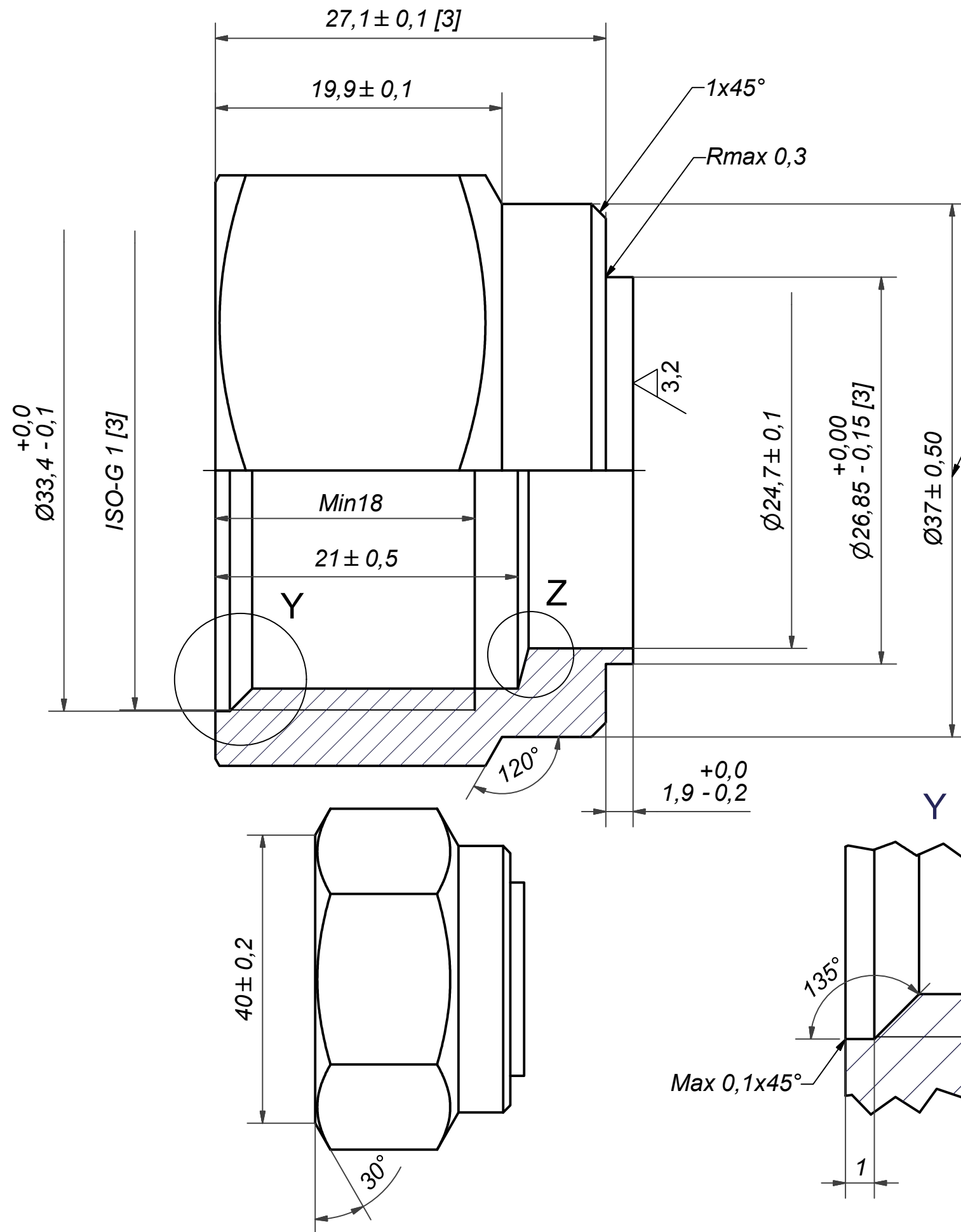

© Company Confidential, Property of SWEP International AB

NOTE 2: DEBURR SHARP EDGES ; MAX 0,4
NOTE 1:[3] - CRITICAL/SPECIAL CHARACTERISTIC TO BE FOLLOWED

ACCORDING TO MQS
MATERIAL

Drawn	Checked	Approved	Created Date	General geometrical tolerancing ISO 2768:	General surface finish R_a :	Scale	Paper size
miguser	TP	VP	1991-11-06	m	3.2	-	A3
			Title				
			ISO-G 1 INT. HEX.				
Article number			Design Type	Drawing number	Revision	Sheet	
-			CD	CD000001	14	1 (1)	