



NOTE 1 ALTERNATE MARKING: STICKER OR STAMP

F4	45397	ISO-G 1 INT. HEX., TH = 27,1	CD000001
F3	45428	ISO-G 1 1/4 (INT- HEX), TH = 27,1	CD000002
F2	45397	ISO-G 1 INT. HEX., TH = 27,1	CD000001
F1	45428	ISO-G 1 1/4 (INT- HEX), TH = 27,1	CD000002
Pos	Article No	Title / Denomination, code, material, dimension etc	Drawing No./ref

Pos	Article No	Title / Denomination, code, material, dimension etc	Drawing No./ref
-----	------------	---	-----------------

Title		B25TH/1P-SC-S	
 A DOVER COMPANY	Created Date	Created By	
	2025-01-04	AU	
	Article/Configuration number	Drawing number	
	085622.0	AU00075582_085622.0	

Rev No	Alteration	Date	Checked	Approved
07	ADDED DIMENSION. UPDATED TITLE.	24. 1. 2013	SKZE	VP

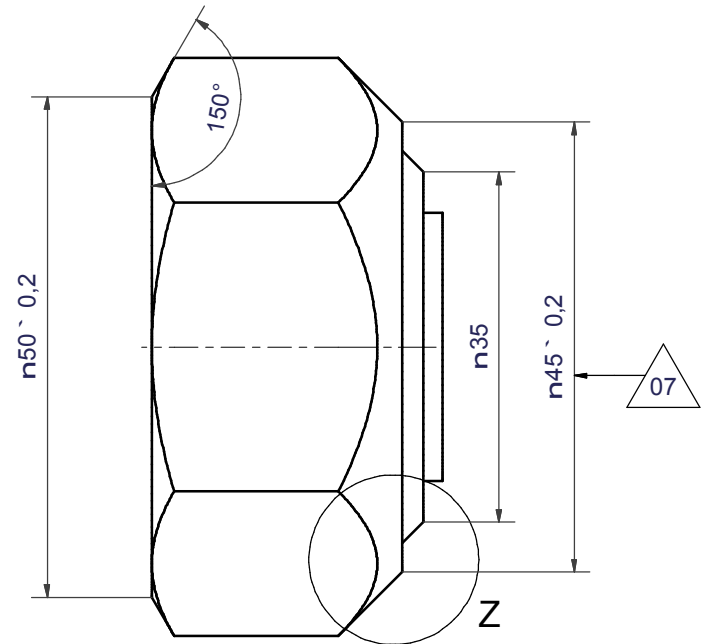
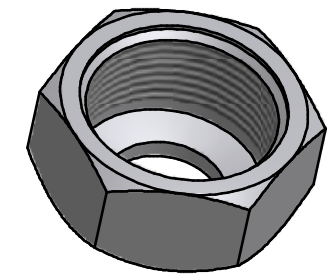
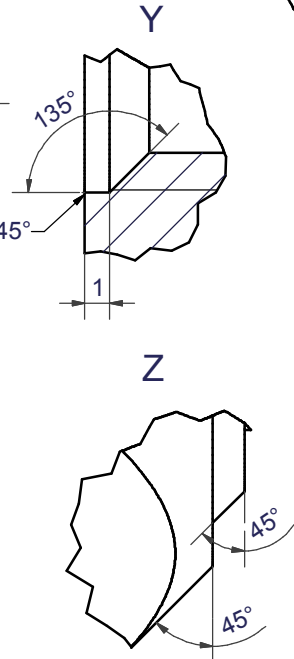
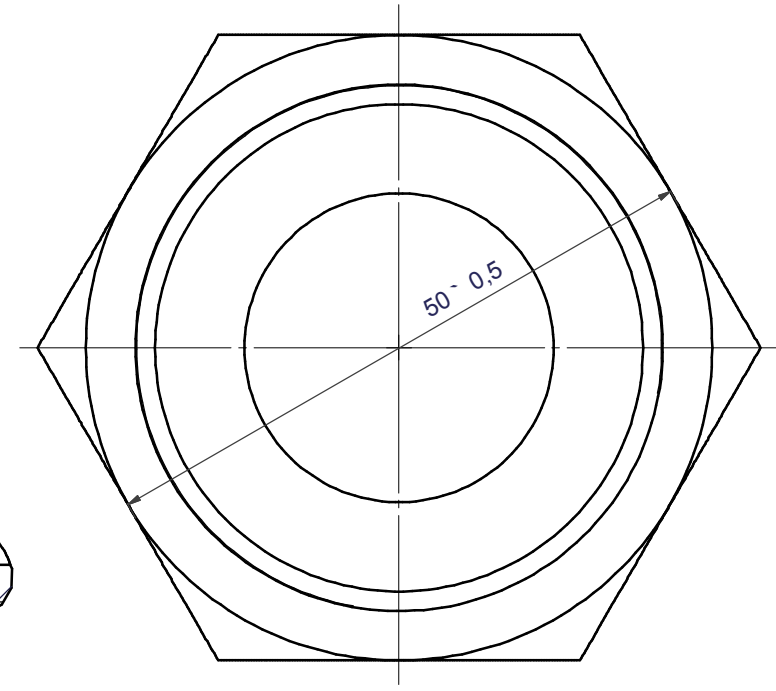
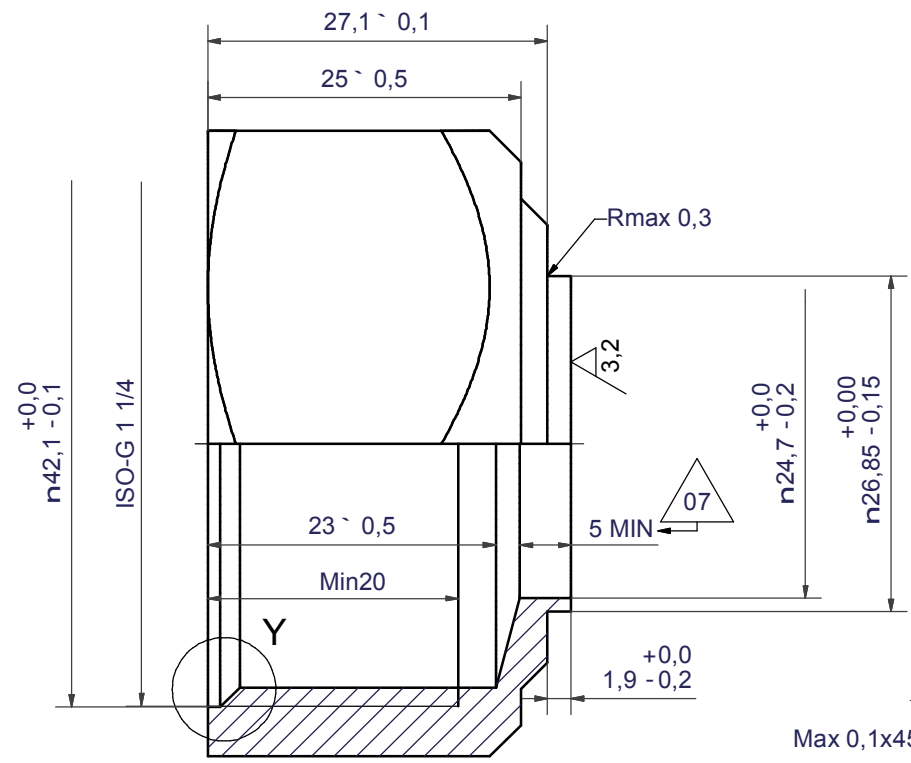

NOTE 1: DEBURR SHARP EDGES; MAX 0.4

ACCORDING TO MQS
MATERIAL

Drawn	Checked	Approved	Created Date	General geometrical tolerancing ISO 2768	General surface finish R_a	Scale	Paper size
HR	TP	VP	31. 8. 1992	m	3.2	-	A3
			Title ISO-G 1 1/4 (INT- HEX)				
Article / Tool number		Design Type	Drawing number	Revision	Sheet		
CD		CD	CD000002	07	1 (1)		

Rev No	Alteration	Date	Checked	Approved
14	DIMENSION CORRECTED	2014-06-02	SKMTB	VP

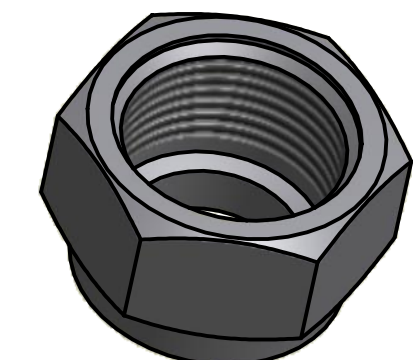
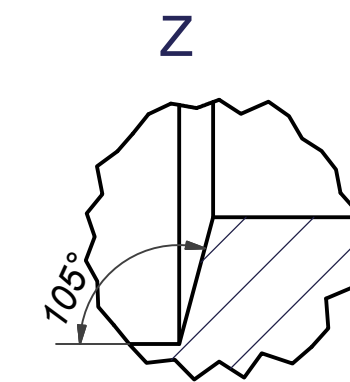
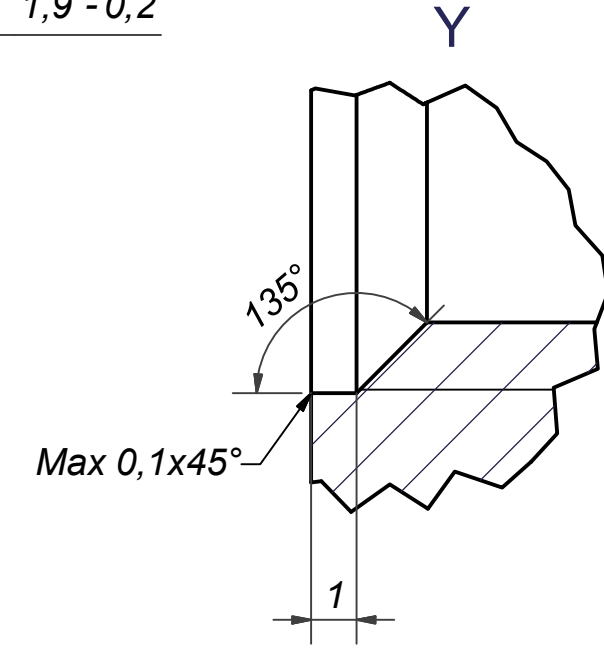
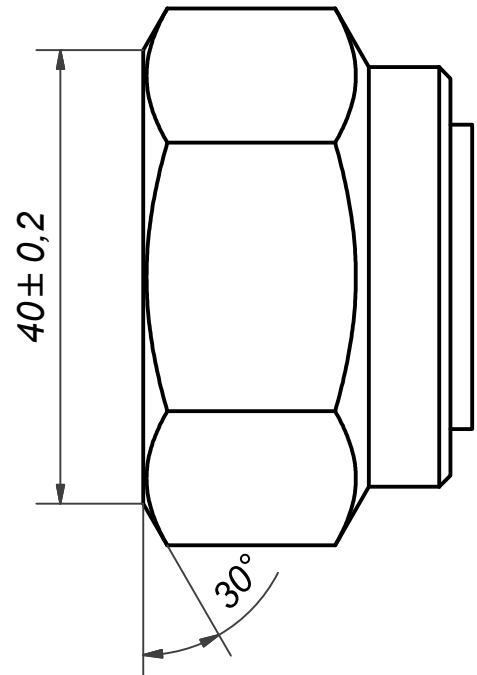
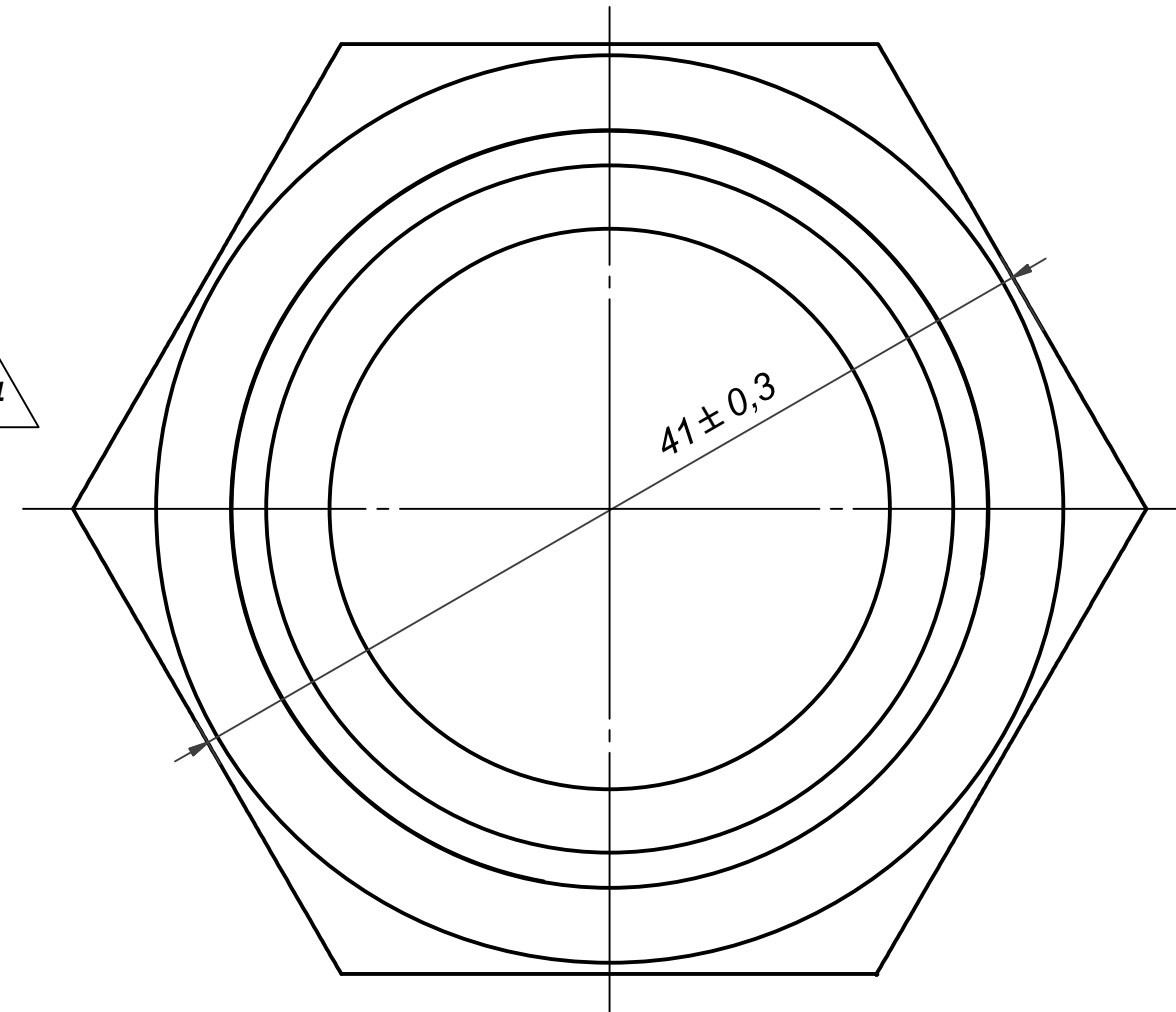
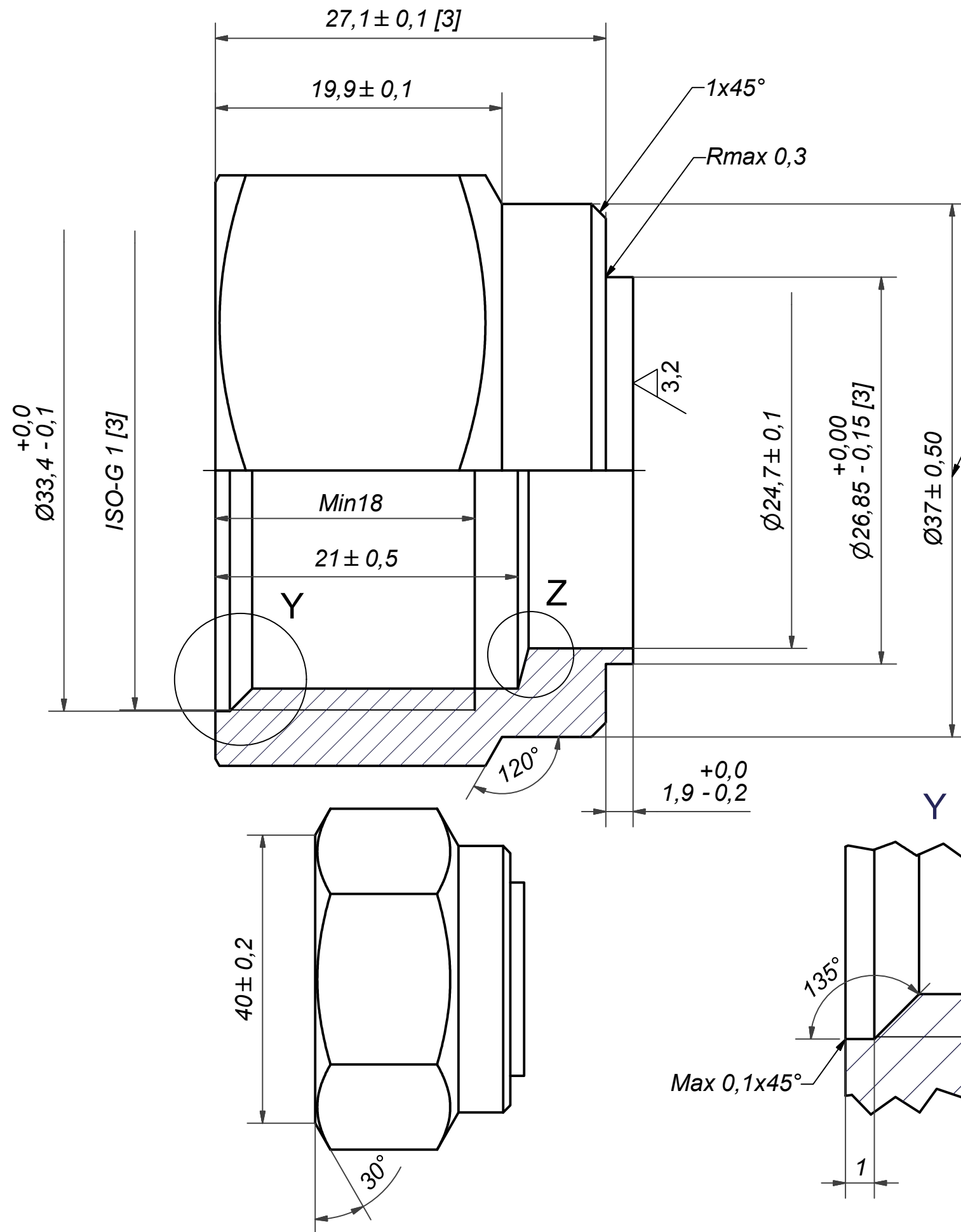

NOTE 2: DEBURR SHARP EDGES ; MAX 0,4
NOTE 1:[3] - CRITICAL/SPECIAL CHARACTERISTIC TO BE FOLLOWED

ACCORDING TO MQS
MATERIAL

Drawn	Checked	Approved	Created Date	General geometrical tolerancing ISO 2768:	General surface finish R_a :	Scale	Paper size
miguser	TP	VP	1991-11-06	m	3.2	-	A3
				ISO-G 1 INT. HEX.			
Article number	Design Type	Drawing number	Revision	Sheet			
-	CD	CD000001	14	1 (1)			