

NOTE 1 ALTERNATE MARKING: STICKER OR STAMP

F4	45427	ISO-G 1 1/4" INT HEX, TH = 27,1	CD000008
F3	45405	ISO-G 1 1/2" INT HEX, TH = 27,1	CD000003
F2	45427	ISO-G 1 1/4" INT HEX, TH = 27,1	CD000008
F1	45405	ISO-G 1 1/2" INT HEX, TH = 27,1	CD000003

Pos	Article No	Title / Denomination, code, material, dimension etc	Drawing No./ref	Pos	Article No	Title / Denomination, code, material, dimension etc	Drawing No./ref
-----	------------	---	-----------------	-----	------------	---	-----------------

Title		B35TM0/1P-SC-S	
	Created Date	2025-01-04	Created By
	Article/Configuration number	0203359.0	Drawing number
			AU
			AU00075588_0203359.0

Rev No.	Alteration	Date	Checked	Approved
9	ADDED DEBURR AND MATERIAL INFO	2009/07/28	RJ	PDM

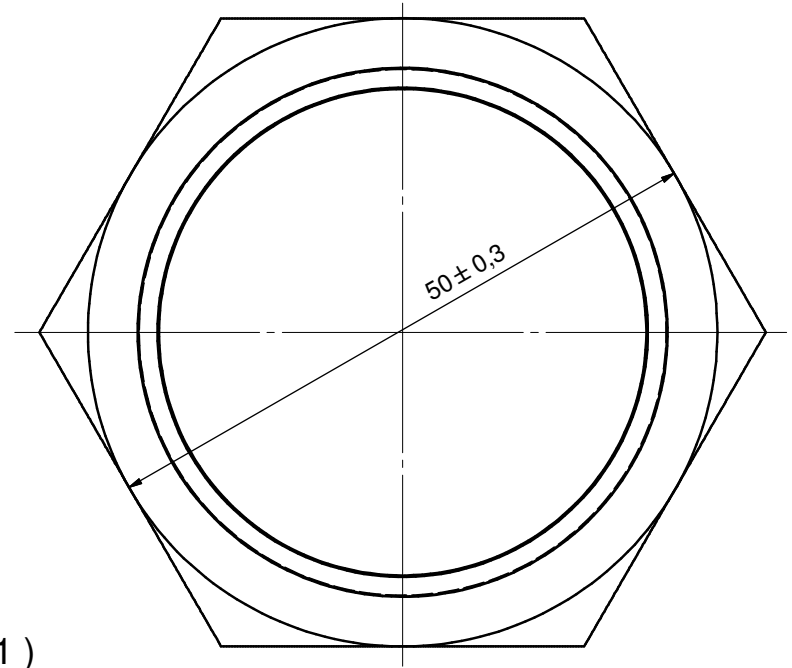
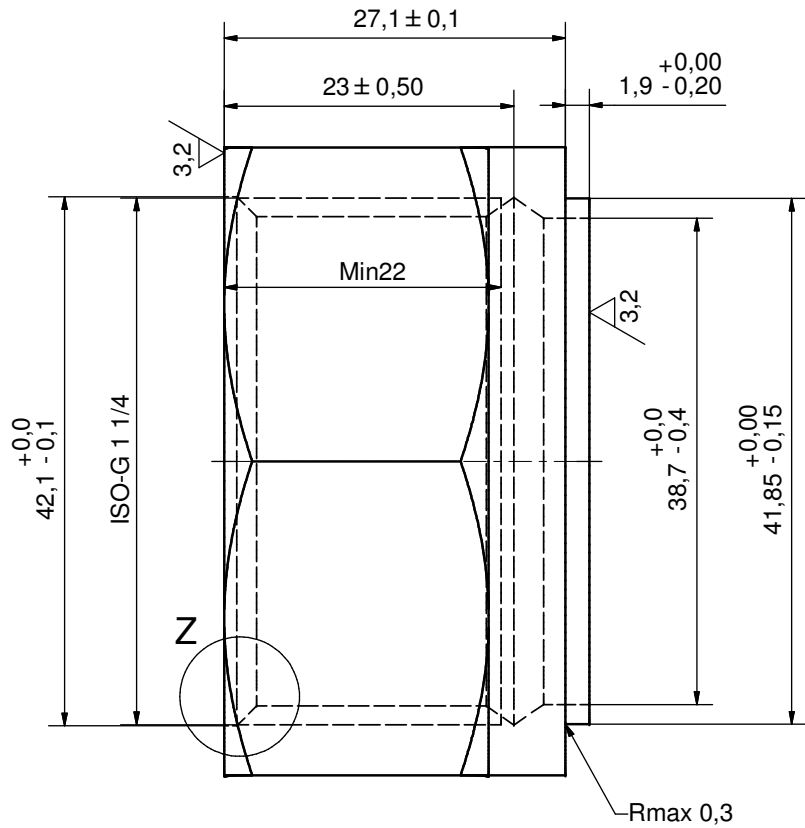

Z (5 : 1)

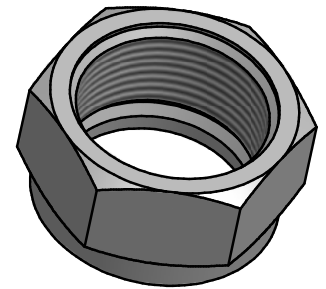
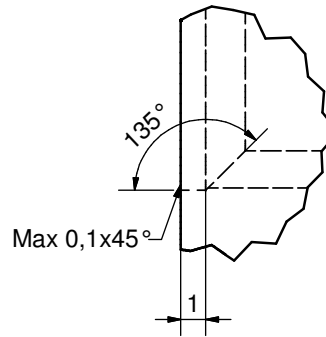
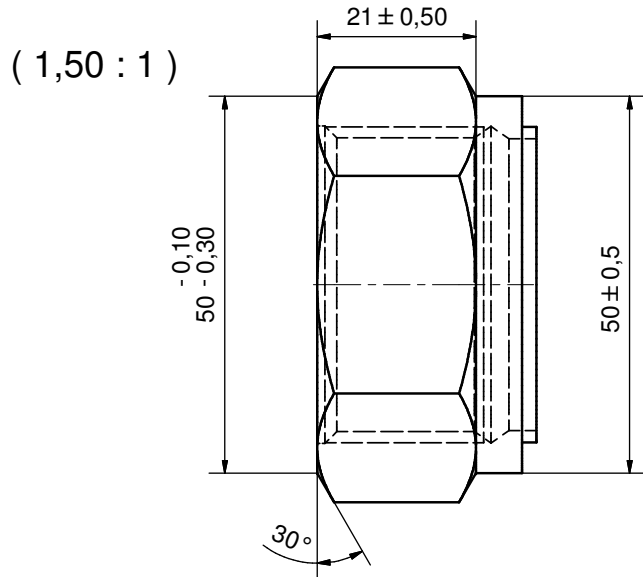

DEBURR SHARP EDGES; 0.4MAX

ACCORDING TO MQS  
MATERIAL

Drawn	Checked	Approved	Created Date	General geometrical tolerancing ISO 2768	General surface finish Ra	Scale
EG	TP	VP	1992-08-21	m	3.2	-
			Title <b>ISO-G 1 1/4" INT HEX</b>			
Article number		Drawing number		Revision	Sheet	
-		CD000008		9	1 (1)	

Rev No.	Alteration	Date	Checked	Approved
12	Changed "G" dimension from 25 to 23.5mm	2010/09/16	SKMZP	PDM

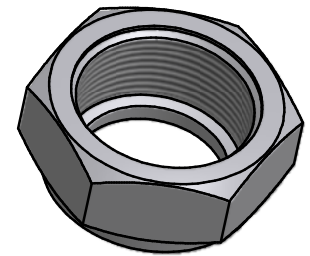
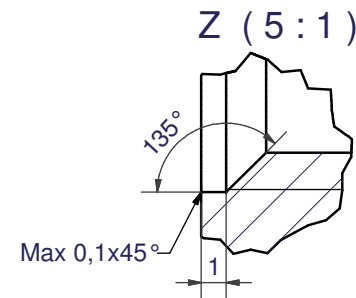
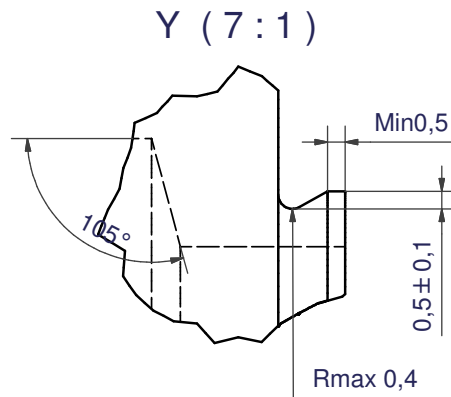
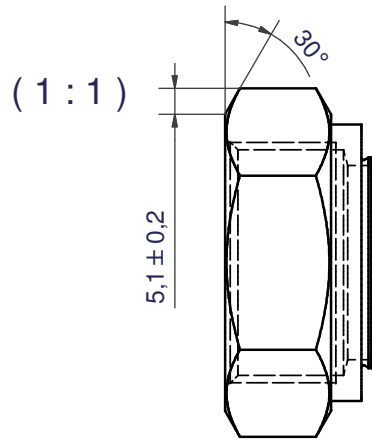
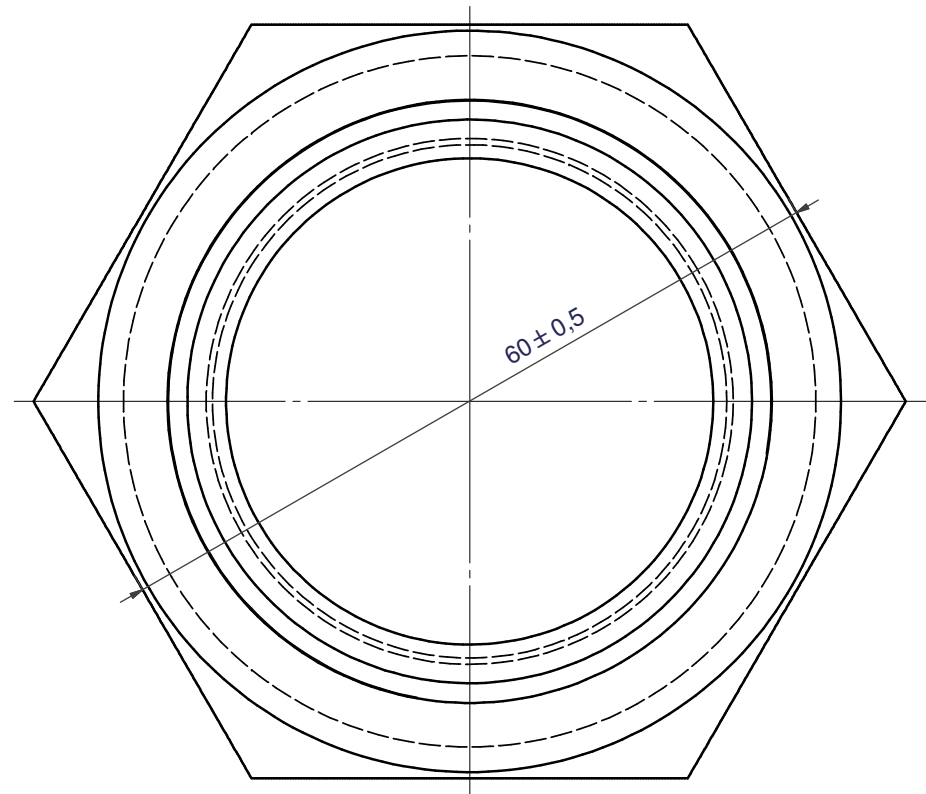
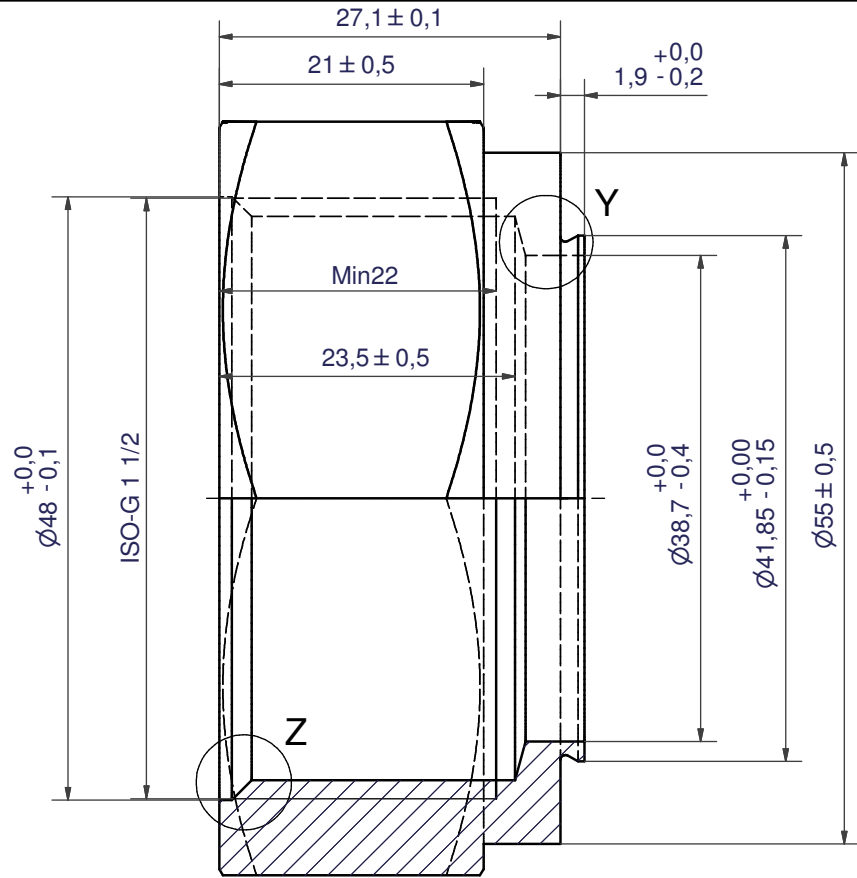

DEBURR SHARP EDGES; 0.4MAX

ACCORDING TO MQS  
MATERIAL

Drawn	Checked	Approved	Created Date	General geometrical tolerancing ISO 2768	General surface finish $R_a$	Scale
EG	TP	VP	1992-05-05	m	3.2	-
			<b>ISO-G 1 1/2" INT HEX</b>			
Article number		Drawing number		Revision	Sheet	
-		CD000003		12	1 (1)	