

NOTE 1 ALTERNATE MARKING: STICKER OR STAMP

| | | | |
|----|-------|------------------------------|----------|
| F4 | 45411 | ISO-G 1/2 INT HEX, TH = 20,1 | CD000005 |
| F3 | 45429 | ISO-G 3/4, TH = 20,1 | CD000007 |
| F2 | 45411 | ISO-G 1/2 INT HEX, TH = 20,1 | CD000005 |
| F1 | 45429 | ISO-G 3/4, TH = 20,1 | CD000007 |

| Pos | Article No | Title / Denomination, code, material, dimension etc | Drawing No./ref | Pos | Article No | Title / Denomination, code, material, dimension etc | Drawing No./ref |
|-----|------------|---|-----------------|-----|------------|---|-----------------|
|-----|------------|---|-----------------|-----|------------|---|-----------------|

| | | | |
|-------|------------------------------|----------------------|----------------|
| Title | | B5TH/1P-SC-M | |
| | Created Date | 2025-01-04 | Created By |
| | Article/Configuration number | 0135436.0 | Drawing number |
| | | AU | |
| | | AU00075568_0135436.0 | |

| Rev No | Alteration | Date | Checked | Approved |
|--------|--------------------------------------|------------|---------|----------|
| 10 | Design Changed according to RD100928 | 2012-04-26 | INRJ | PDM |

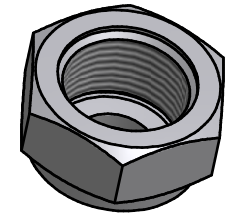
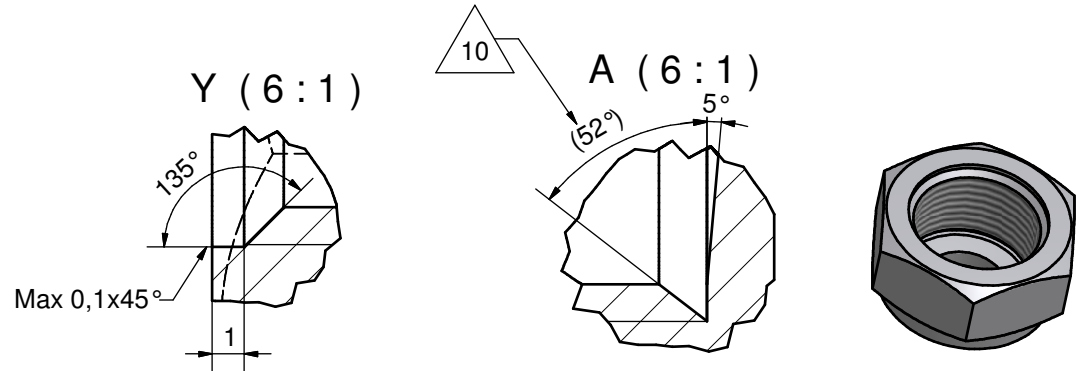
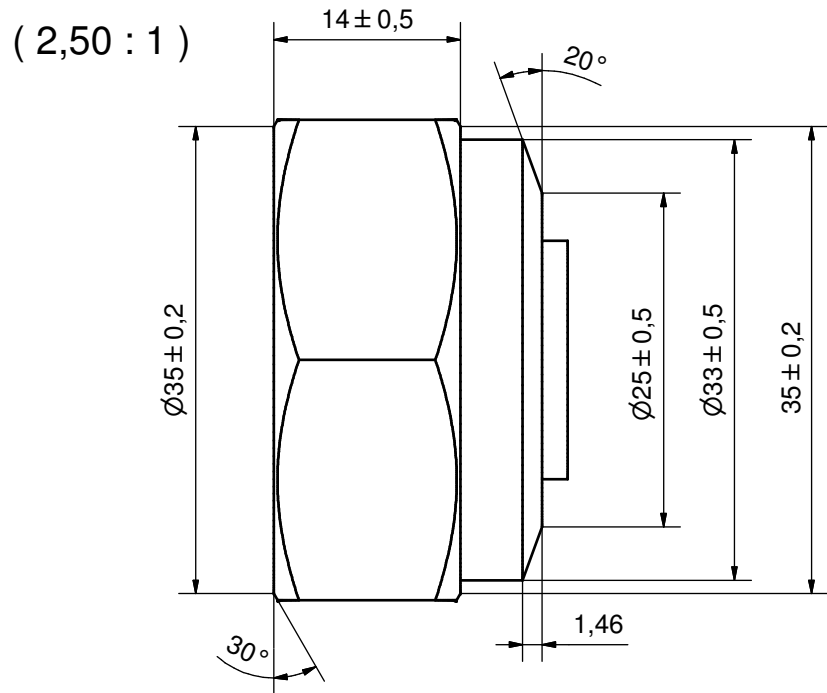
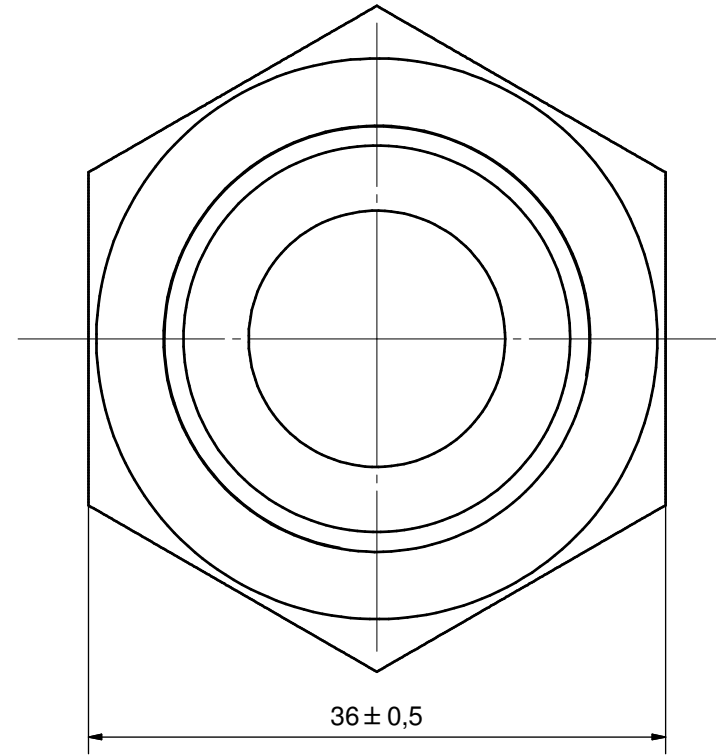
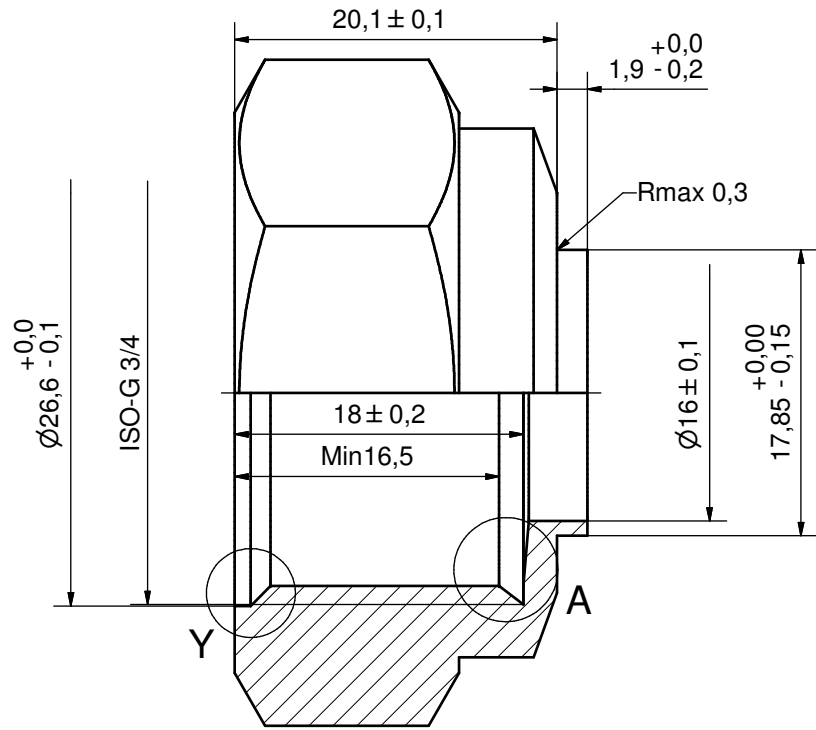



DEBURR SHARP EDGES; MAX 0.4

ACCORDING TO MQS
MATERIAL

| | | | | | | | |
|---|---------------|-----------------|----------------------------|--|---|------------|------------------|
| Drawn HR | Checked TP | Approved PDM | Created Date 1992-08-31 | General geometrical tolerancing ISO 2768 m | General surface finish R _a : 3.2 | Scale - | Paper size A3 |
|  | | | Title ISO-G 3/4 | | | | |
| Article / Tool number | | Design Type | Drawing number | Revision | Sheet | | |
| | | CD | CD000007 | 10 | 1 (1) | | |

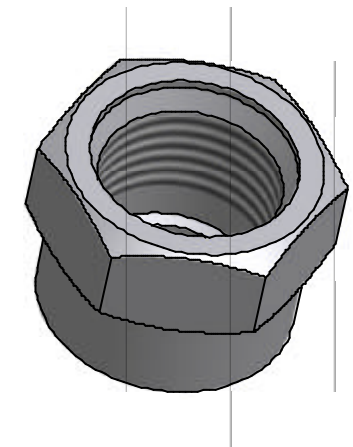
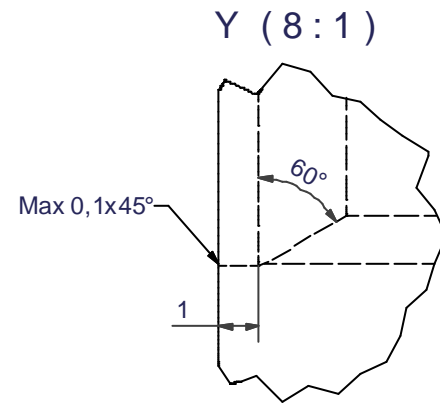
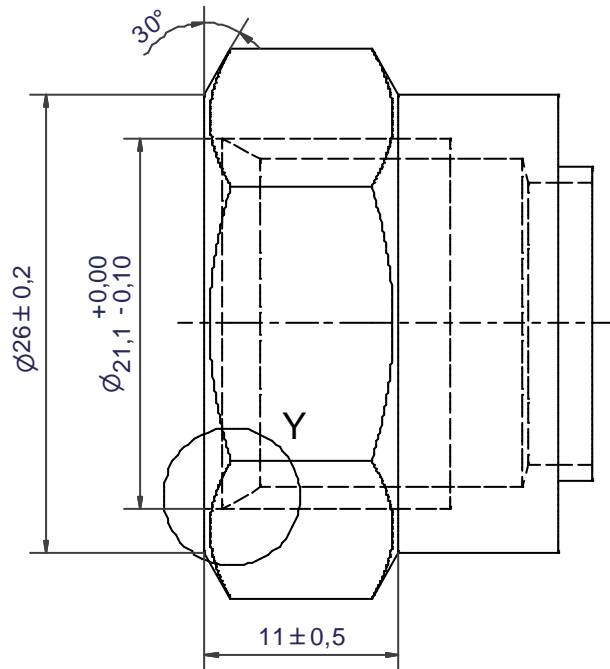
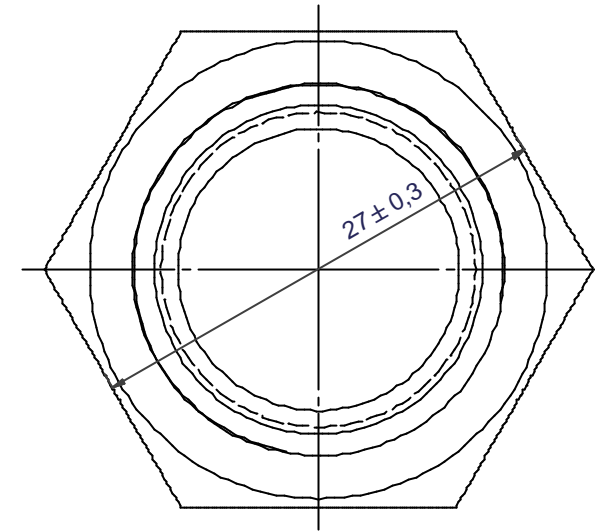
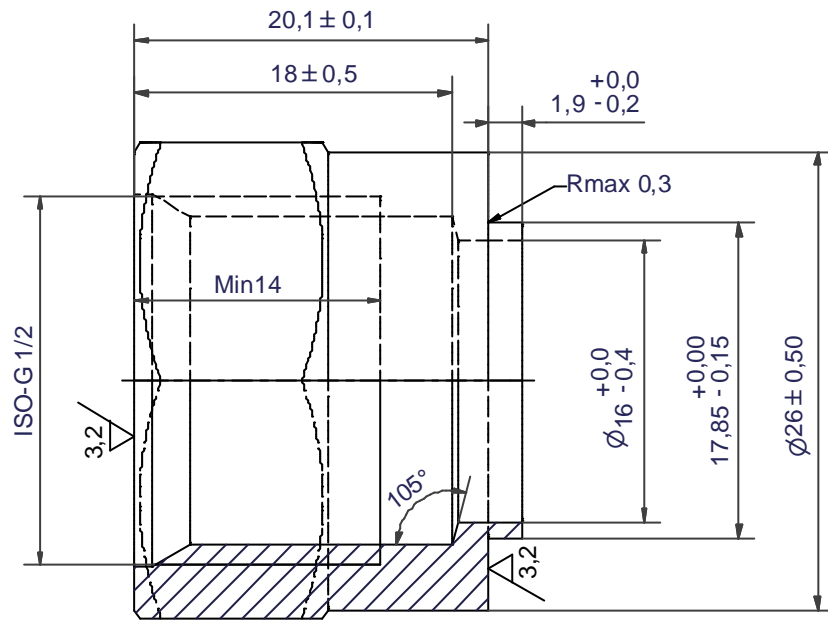
| Rev No. | Alteration | Date | Checked | Approved |
|---------|---------------------|------------|---------|----------|
| 10 | REDRAWN IN INVENTOR | 2004/07/06 | TN | PDM |



| | | | | | | |
|---|---------------|----------------|-----------------------------------|--|---|--------------|
| Drawn HR | Checked TP | Approved VP | Created Date 1992/05/05 | General geometrical tolerancing ISO 2768 m | General surface finish R _a 3,2 | Scale 7:2 |
|  | | | Title ISO-G 1/2 INT HEX | | | |
| Article number - | | | Drawing number CD000005 | | Revision 10 | |
| | | | Sheet 1 (1) | | | |