

NOTE 1 ALTERNATE MARKING: STICKER OR STAMP

F4	45411	ISO-G 1/2 INT HEX, TH = 20,1	CD000005
F3	45429	ISO-G 3/4, TH = 20,1	CD000007
F2	45411	ISO-G 1/2 INT HEX, TH = 20,1	CD000005
F1	45429	ISO-G 3/4, TH = 20,1	CD000007

Pos	Article No	Title / Denomination, code, material, dimension etc	Drawing No./ref	Pos	Article No	Title / Denomination, code, material, dimension etc	Drawing No./ref
-----	------------	---	-----------------	-----	------------	---	-----------------

Title		B8TH/1P-SC-M	
	Created Date	2025-01-04	Created By
	Article/Configuration number	0125844.0	Drawing number
			AU
			AU00075564_0125844.0

Rev No	Alteration	Date	Checked	Approved
10	Design Changed according to RD100928	2012-04-26	INRJ	PDM

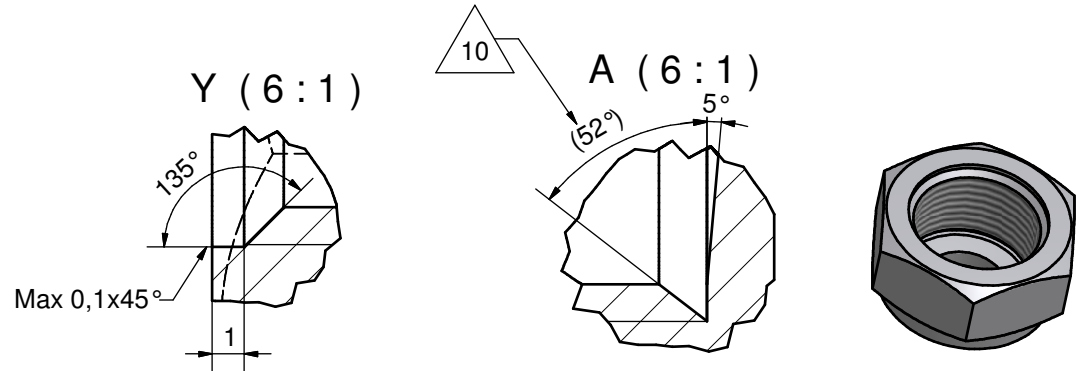
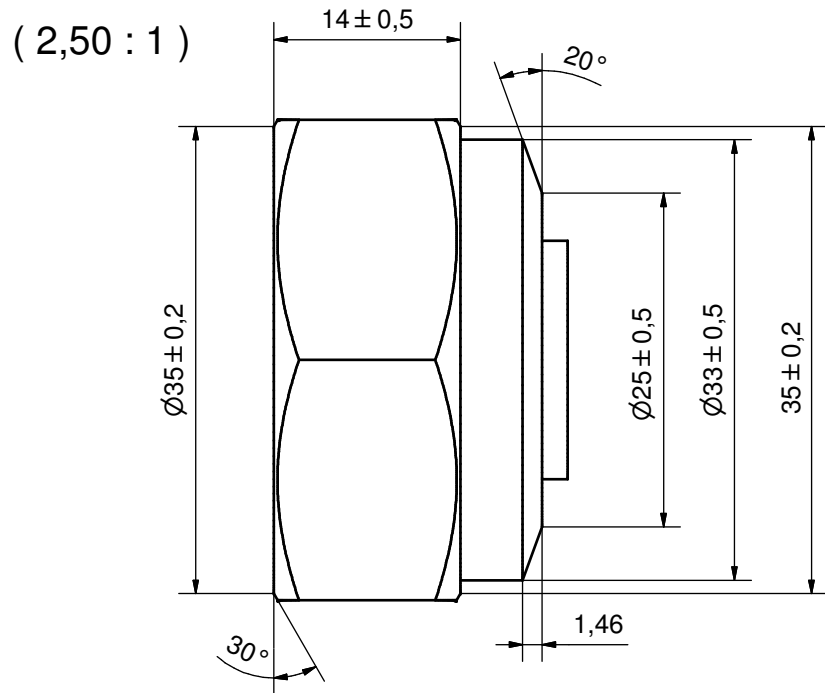
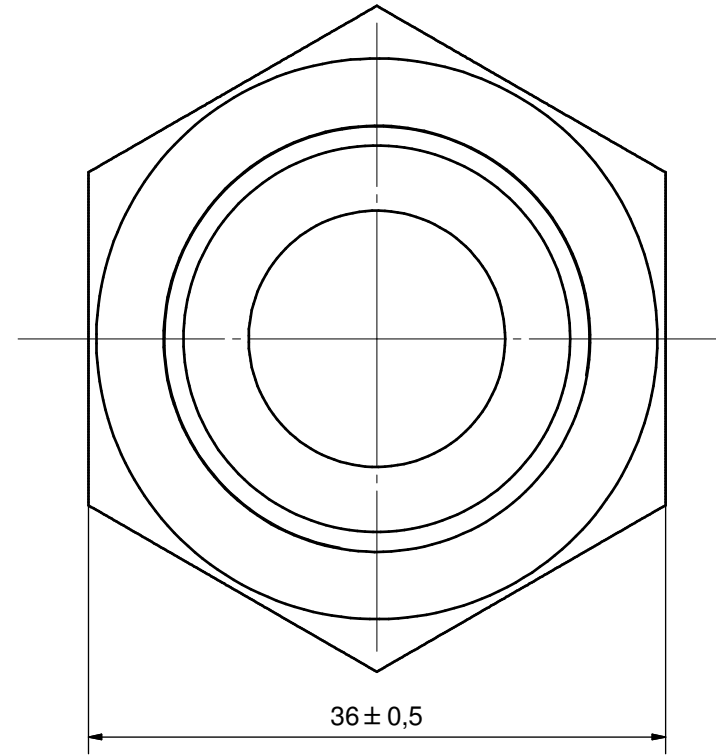
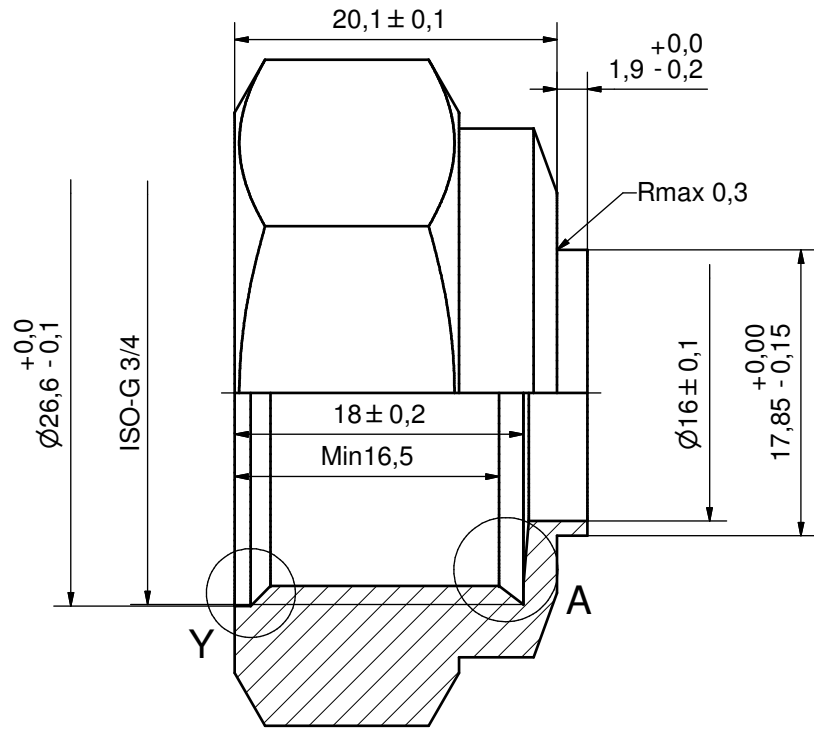

DEBURR SHARP EDGES; MAX 0.4

ACCORDING TO MQS
MATERIAL

Drawn HR	Checked TP	Approved PDM	Created Date 1992-08-31	General geometrical tolerancing ISO 2768 m	General surface finish R_a : 3.2	Scale -	Paper size A3
			Title ISO-G 3/4				
Article / Tool number		Design Type CD	Drawing number CD000007		Revision 10	Sheet 1 (1)	

Rev No.	Alteration	Date	Checked	Approved
10	REDRAWN IN INVENTOR	2004/07/06	TN	PDM

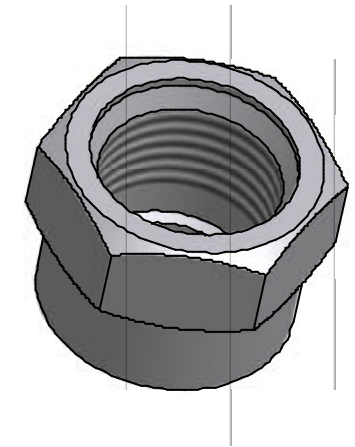
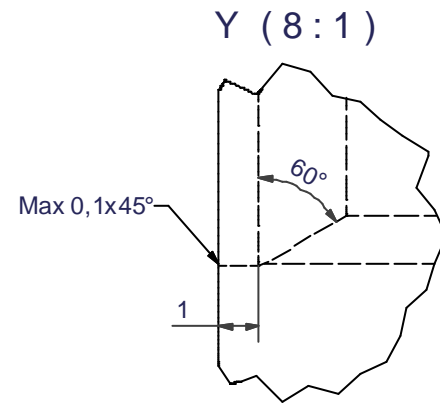
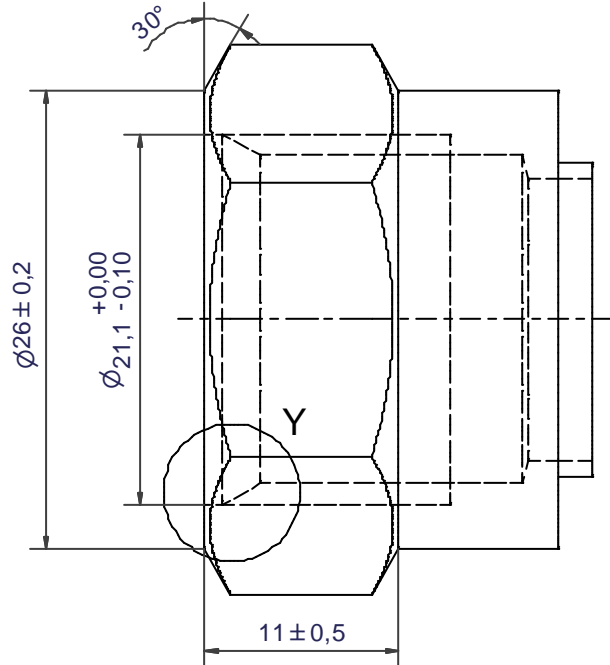
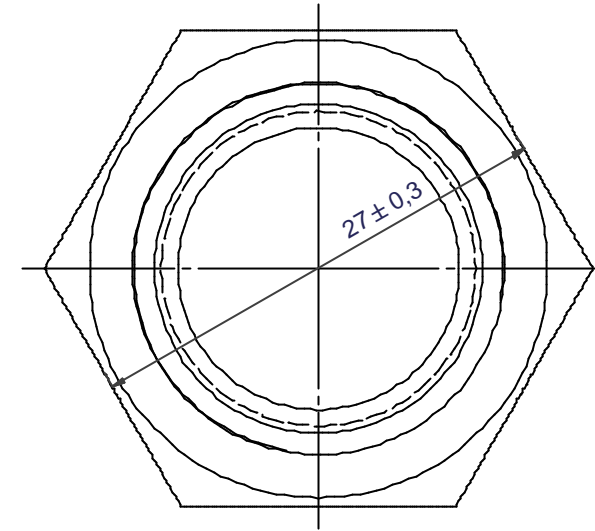
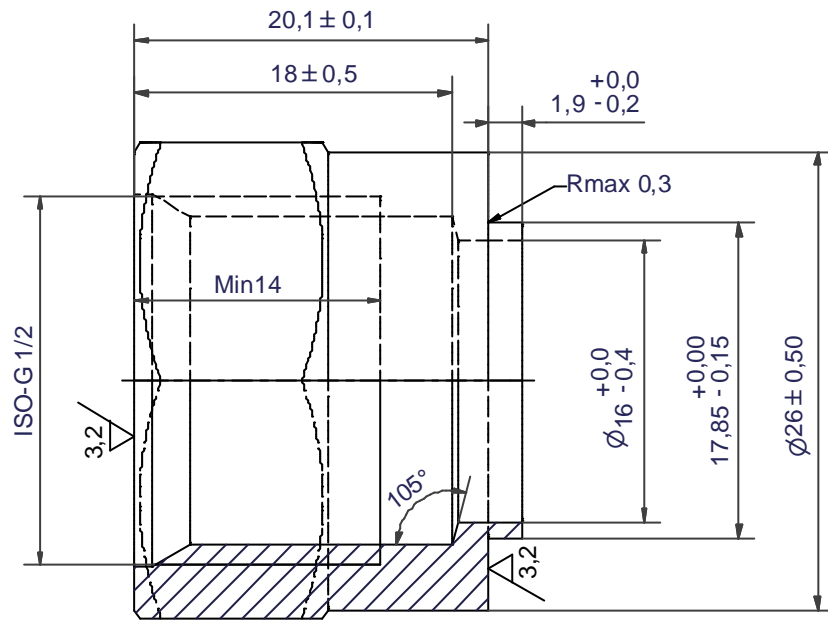

Drawn HR	Checked TP	Approved VP	Created Date 1992/05/05	General geometrical tolerancing ISO 2768 m	General surface finish R _a 3.2		Scale 7:2
			Title ISO-G 1/2 INT HEX				
Article number -			Drawing number CD000005		Revision 10		Sheet 1 (1)